

Please inform us of any requests with this form.

Specification Form for Custom-designed Caster

Name : _____

Company name : _____

Division : _____ Title : _____ Business category : _____

Address : 〒 _____

TEL : _____ FAX : _____ E-mail : _____

Shipping address : _____

1. Manufacturing Conditions

① Wheel diameter ϕ _____

② Wheel material
 A. SBR B. Polyurethane C. Nylon 6 (Color : _____)
 D. BR (Color : _____) E. MC
 F. Others (_____)

③ Load capacity _____ kg

④ Total weight _____ kg (including vehicle weight)

⑤ Bracket material
 A. Steel (Specified material _____)
 B. Stainless steel (SUS 304/Others : _____)
 C. Cast metal
 D. Others (_____)

⑥ Required quantity _____ pcs.

⑦ Remarks
 (Please also use the next page for your additional instructions.)

FAX No. +81-76-2734505

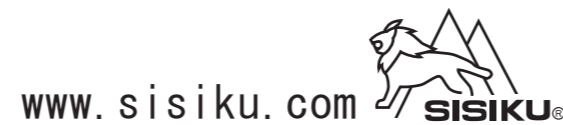

Swivel Caster

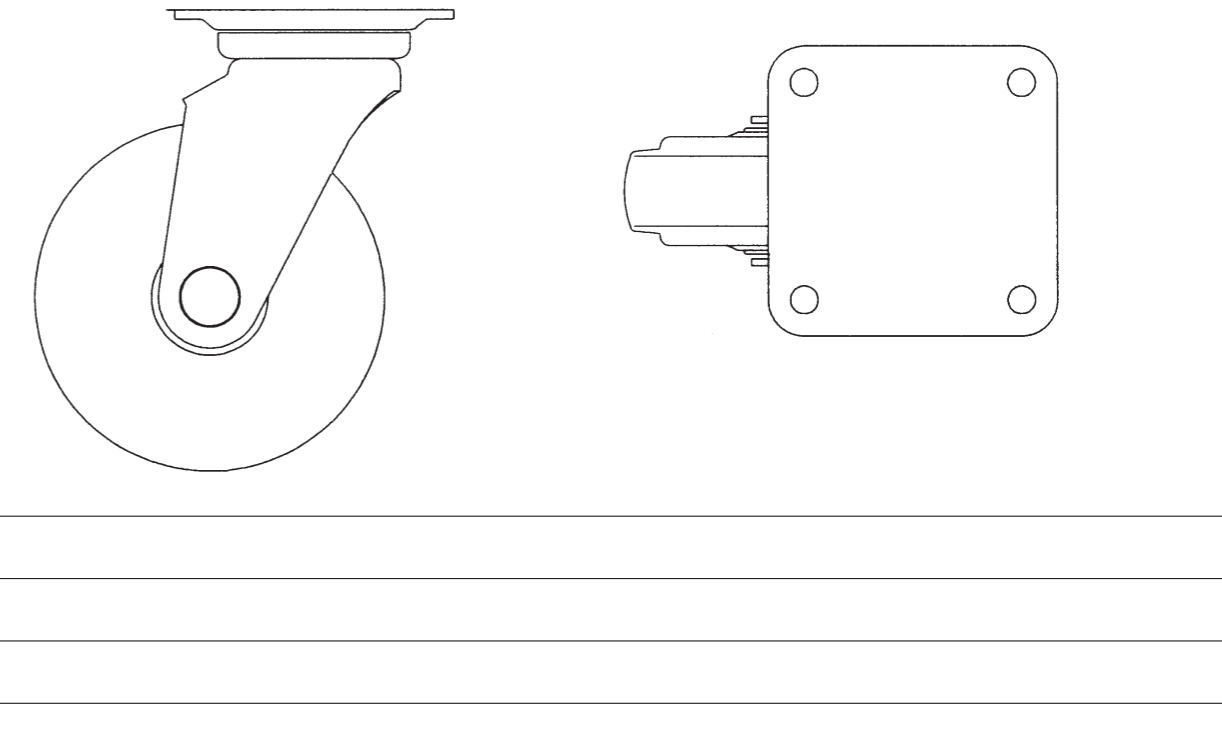

Fixed Caster

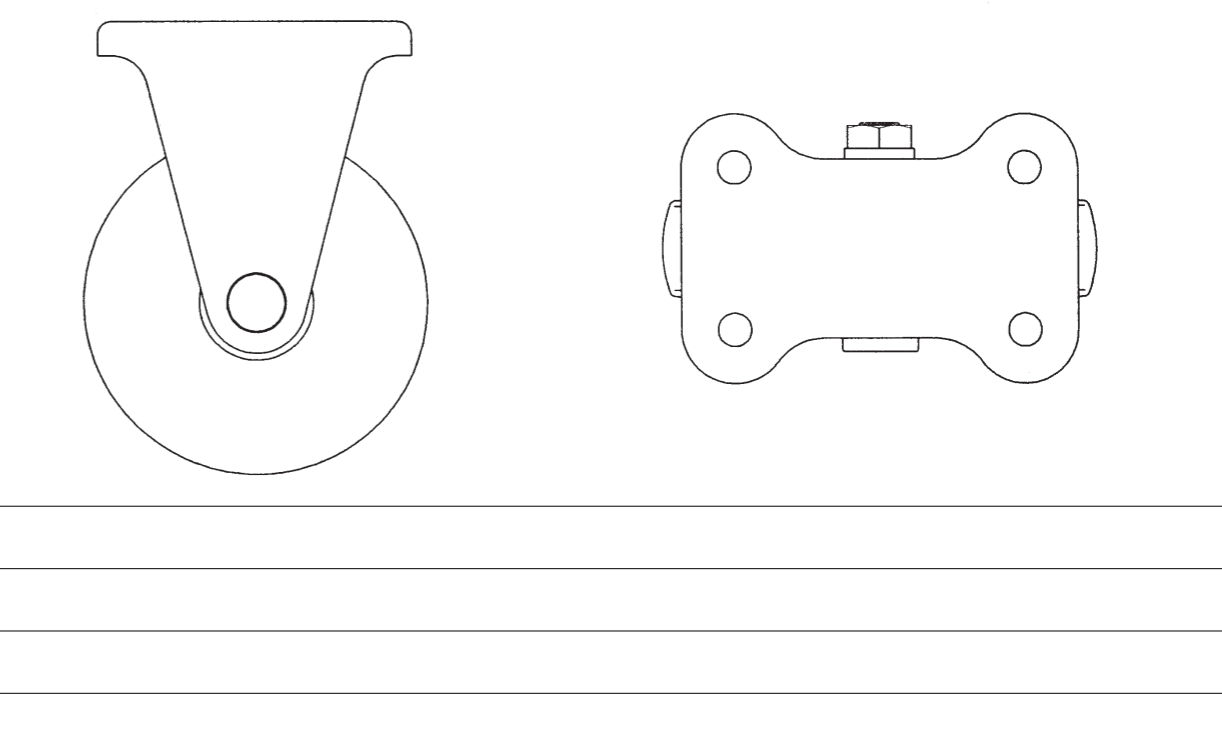

FAX No. +81-76-2734505

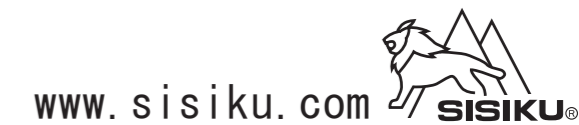

※Please copy this form and inform us of your requests by fax.
 You can also download the same from our web site.